

Cartridge cylinder single acting/push

CAT Series

● Bore size: $\phi 6/\phi 10/\phi 15$

JIS symbol ● Single acting cylinder 



Specifications

Item	CAT		
Bore size mm	$\phi 6$	$\phi 10$	$\phi 15$
Actuation	Single acting push (spring return method)		
Working fluid	Compressed air		
Max. working pressure MPa	0.7 (≈ 100 psi, 7 bar)		
Min. working pressure MPa	0.2 (≈ 29 psi, 2 bar)	0.15 (≈ 22 psi, 1.5 bar)	
Proof pressure MPa	1.05 (≈ 150 psi, 10.5 bar)		
Ambient temperature °C	-10 (14°F) to 60 (140°F) (no freezing)		
Port size	M5		
Stroke tolerance mm	+1.0		
	0		
Working piston speed mm/s	50 to 500		
Cushion	None		
Lubrication	Not required (use turbine oil class 1 ISO VG32 if necessary for lubrication)		
Allowable absorbed energy J	This product cannot absorb the energy generated by an external load mounted on the cylinder.		
	When using the product with no load, separately provide a shock absorber on the outside.		

*1: Do not leave the single acting cylinder pressurized for a long time. If it is left pressurized for long periods, the piston rod may not return due to spring load when the pressure is released.

Stroke length

Bore size (mm)	Standard stroke length (mm)
$\phi 6$	5/10/15
$\phi 10$	
$\phi 15$	

Note: Products with stroke length other than standard stroke length are not available.

Cylinder weight

(Unit: g)

Stroke length (mm)	5	10	15
Bore size (mm)			
$\phi 6$	18.0	21.0	23.0
$\phi 10$	43.5	50.0	56.0
$\phi 15$	100.0	114.5	128.0

Spring load (load when pulling) (Unit: N)

Bore size (mm)	Stroke length (mm)	When stroke length = 0	At full stroke
$\phi 6$	5	1.92	3.85
	10	1.37	3.33
	15	1.17	3.66
$\phi 10$	5	3.92	6.8
	10	3.43	7.4
	15	2.94	9.04
$\phi 15$	5	5.88	8.82
	10	4.41	8.82
	15	3.92	9.8

Theoretical thrust (push)

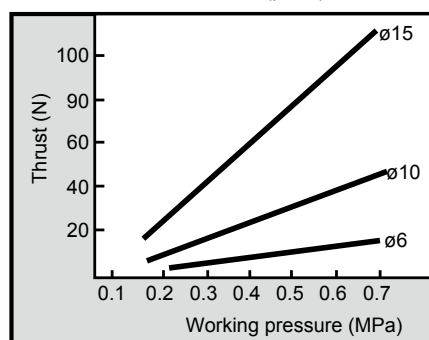

How to order

Without switch

CAT - N - 6 - 5 - M

A Mounting

B Bore size

C Stroke length

D Piston rod end

Code	Description
A Mounting	
N	Panel mount
O	Inset
B Bore size (mm)	
6	ø6
10	ø10
15	ø15
C Stroke length (mm)	
5	5
10	10
15	15
D Piston rod end	
M	Male thread
F	No thread

[Example of model No.]

CAT-N-6-5-M

Model: Cartridge cylinder, single acting/push

- A** Mounting : Panel mount
- B** Bore size : ø6 mm
- C** Stroke length : 5 mm
- D** Piston rod end : Male thread

SCP*3

CMK2

CMA2

SCM

SCG

SCA2

SCS2

CKV2

CAV2/
COVP/N2

SSD2

SSG

SSD

CAT

MDC2

MVC

SMG

MSD/
MSDG

FC*

STK

SRL3

SRG3

SRM3

SRT3

MRL2

MRG2

SM-25

ShkAbs

FJ

FK

Spd
Contr

Ending

Internal structure and parts list

- SCP*3
- CMK2
- CMA2
- SCM
- SCG
- SCA2
- SCS2
- CKV2
- CAV2/
COVPIN2
- SSD2
- SSG
- SSD
- CAT**
- MDC2
- MVC
- SMG
- MSD/
MSDG
- FC*
- STK
- SRL3
- SRG3
- SRM3
- SRT3
- MRL2
- MRG2
- SM-25
- ShkAbs
- FJ
- FK
- Spd
Contr
- Ending

● Panel mount (N)

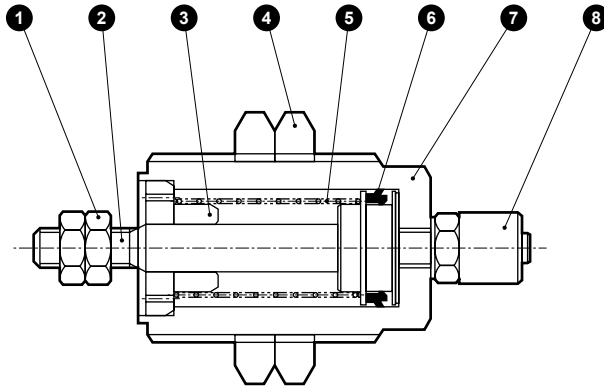

● Inset (O)

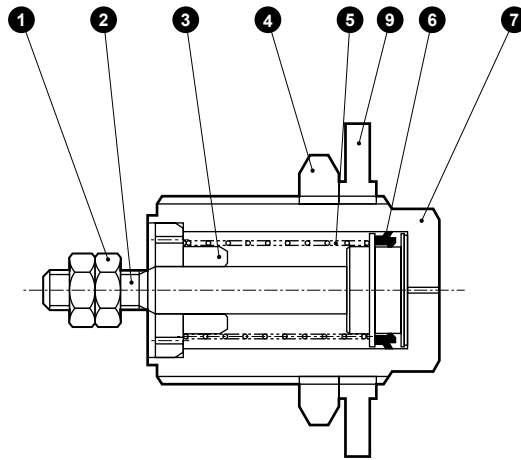

Cannot be disassembled

No.	Part name	Material	Remarks	No.	Part name	Material	Remarks
1	Hexagon nut	Stainless steel		5	Coil spring	Steel	Electrodeposition
				6	Piston packing	Nitrile rubber	
2	Piston rod	Stainless steel		7	Body	Copper alloy	Nickeling
3	Rod cover	Phosphor bronze	Nickeling	8	Clamping nipple		
4	Nut	Copper alloy	Nickeling	9	Seal washer	Nitrile rubber, steel	

Note: This product cannot be disassembled.

Dimensions



● Panel mount (N)

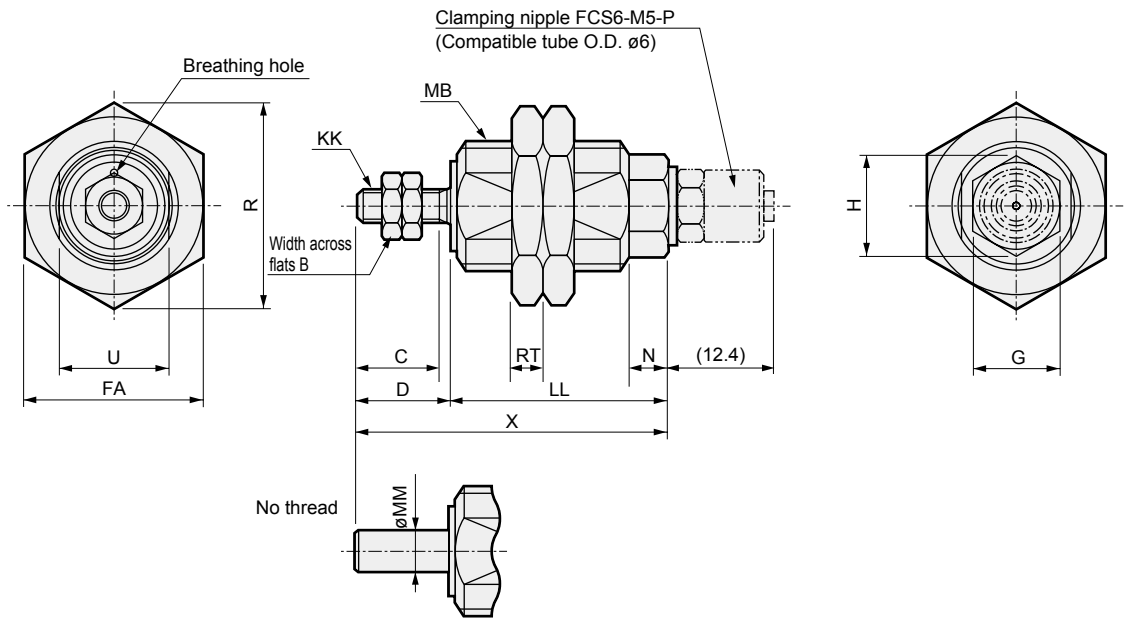

Note: For air piping, use the included clamping nipple (orifice size ø0.8).

Code	B	C	D	FA	G	H	KK	LL			MB	MM	N	R	RT	U	X		
								Stroke length									Stroke length		
								5	10	15							5	10	15
ø6	5.5	7	8.5	14	7 ⁰ _{-0.2}	8.1	M3	19	26	32	M10×1	3	5	16.2	3	8 ⁰ _{-0.2}	27.5	34.5	40.5
ø10	7	10	11.5	22	11 ⁰ _{-0.25}	12.7	M4	21	27	33.5	M16×1.5	5	5	25.4	4	13.5 ⁰ _{-0.25}	32.5	38.5	45
ø15	8	12	13.5	30	18 ⁰ _{-0.25}	20.8	M5	24	30	36	M24×1.5	6	6	34.6	5	22 ⁰ _{-0.35}	37.5	43.5	49.5

● Inset (O)

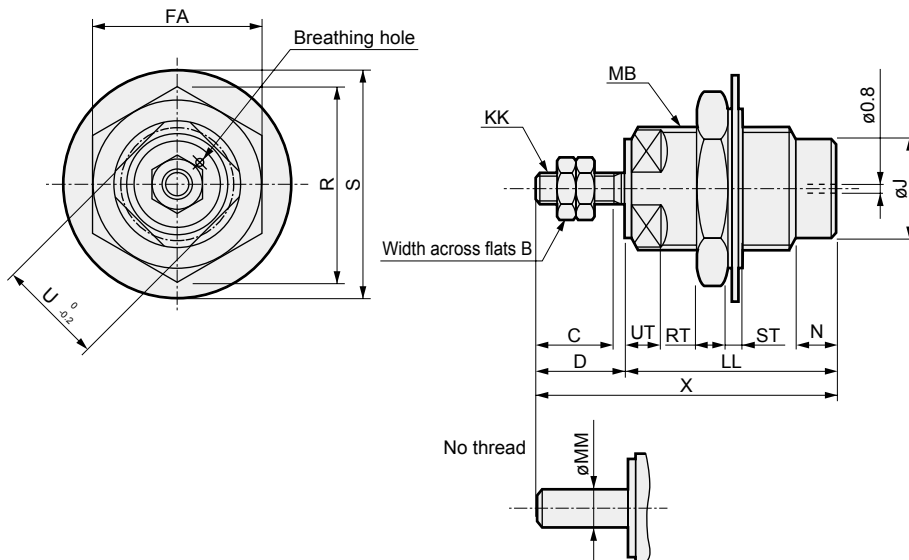

Code	B	C	D	FA	J	KK	LL			MB	MM	N	R	RT	S	ST	U	UT	X		
							Stroke length												Stroke length		
							5	10	15										5	10	15
ø6	5.5	7	8.5	14	8.5	M3	19	26	32	M10×1	3	5	16.2	3	20.3	1.5	9	3.5	27.5	34.5	40.5
ø10	7	10	11.5	22	13	M4	21	27	33.5	M16×1.5	5	5	25.4	4	30.3	2	14	4.5	32.5	38.5	45
ø15	8	12	13.5	30	21	M5	24	30	36	M24×1.5	6	6	34.6	5	42.8	3	22	5.5	37.5	43.5	49.5

- SCP*3
- CMK2
- CMA2
- SCM
- SCG
- SCA2
- SCS2
- CKV2
- CAV2/COVP/N2
- SSD2
- SSG
- SSD
- CAT**
- MDC2
- MVC
- SMG
- MSD/MSDG
- FC*
- STK
- SRL3
- SRG3
- SRM3
- SRT3
- MRL2
- MRG2
- SM-25
- ShkAbs
- FJ
- FK
- Spd Contr
- Ending